



TOUGHSYSTEM® Music + Charger

DWST08810

Premium Sound for the Jobsite

INSTRUCTION MANUAL

1-800-4-DEWALT ▪ www.dewalt.com

KEY FEATURES

- AM/FM-stereo radio with manual/auto scanning and memory preset of stations
- Bluetooth audio connectivity
- Auxiliary jack for connecting external audio devices
- USB power/charging port (5V/1A)
- Large LCD display with illumination
- Illuminated, soft-touch buttons
- Four tweeter drivers and two subwoofers
- for rich sound performance
- Volume control and sound tone adjustment
- Heavy-duty design
- Mounts and locks to the DEWALT DWST08210 ToughSystem® L-Cart Carrier
- Stackable onto any ToughSystem® unit
- Water and dust resistant – IP54 tested

TECHNICAL DATA

Power supply unit (AC/DC power adaptor)	
Power input	100-120VAC 50-60 Hz (Class II)
Power output	24VDC
Current output	2A
Weight	0.3 kg (0.66 lb.)
Appliance	
Power input	24VDC
Power output	USB charge (5V/1A)
IP rating	IP54*
Weight	6.9 kg (15.2 lb.) not including battery pack
Stacking weight (gross)	60 kg (132 lb.)
Battery pack charger	
Battery packs voltage	12VDC / 20VDC
Battery type	Li-ion (slider)
Approx. charging time	90-300 min
Charge current	1.0A
Audio characteristics	
Audio source	AM/FM, Auxiliary jack (3.5 mm), Bluetooth
Sound SPL	100dB @ 1 m
Sound power	40W (class D)
Operation time	8 hours (approx.) fully charged premium 20V MAX* 2 Ah Li-ion battery

* Protected from work site dust, debris and light rain.

Definitions: Safety Guidelines

The definitions below describe the level of severity for each signal word. Please read the manual and pay attention to these symbols.

 **DANGER:** Indicates an imminently hazardous situation which, if not avoided, will result in **death or serious injury**.

 **WARNING:** Indicates a potentially hazardous situation which, if not avoided, could result in death or serious injury.

 **CAUTION:** Indicates a potentially hazardous situation which, if not avoided, **may** result in **minor or moderate injury**.

NOTICE: Indicates a practice not related to personal injury which, if not avoided, **may** result in **property damage**.

IF YOU HAVE ANY QUESTIONS OR COMMENTS ABOUT THIS OR ANY DEWALT TOOL, CALL TOLL FREE AT: **1-800-DEWALT (1-800-433-9258)**



WARNING: To reduce the risk of injury, read the instruction manual.
NOTE: Product **WARNING** label located on the bottom of the appliance.

DWST08810 ToughSystem® Music + Charger

The DWST08810 ToughSystem® Music + Charger is a combination of an AM/FM radio, Bluetooth and auxiliary music player and a DEWALT battery charger. The DWST08810 will charge most DEWALT slider Li-ion batteries. Batteries sold separately.

Important Safety Instructions

1. Read these instructions.
2. Keep these instructions.
3. Pay attention and follow all warnings.
4. Follow all instructions.
5. **DO NOT** use this appliance near water.
6. Read and understand all safety warnings and instructions. Failure to follow the warnings and instructions may result in electric shock, fire and/or serious injury.
7. This appliance shall not be exposed to direct water and no objects filled with liquids, such as bottles, shall be placed on the appliance.
8. Clean only with a dry or damp cloth.
9. To protect the appliance from water or dust, always close the top compartment cover, battery pack cover and the rubber cover of the DC power input port.
10. Use in accordance with the manufacturer's instructions.
11. **DO NOT** place near any naked flame sources such as lighted candles, heat sources such as radiators, heat registers, stoves or other apparatus (including amplifiers) that produce heat.
12. Protect the power cord from being walked on or pinched particularly at plugs, convenience receptacles.
13. Only use attachments/accessories specified by the manufacturer.
14. Use only with a cart, stand, tripod, bracket, or table specified by the manufacturer, or sold with the apparatus. When a cart is used, use **CAUTION** when moving the cart/apparatus combination to avoid injury from tip-over.
15. The AC/DC power adaptor should only be used as the power source for the appliance and for battery charging. To completely disconnect the appliance, the AC/DC power adaptor, should be disconnected from the outlet.
16. Unplug this appliance during lightning storms or when unused for long periods of time.
17. The AC/DC power adaptor should be easily accessible and not obstructed during intended use.
18. Refer all servicing to qualified service personnel. Servicing is required when the appliance has been damaged in any



way, such as power-supply cord or plug is damaged, liquid or direct rain has reached the connectors, the appliance has been exposed to extensive moisture, does not operate normally, or has been dropped and does not operate.

19. This appliance is not intended for use by persons (including children) with reduced physical, sensory or mental capabilities, or lack of experience and knowledge, unless they have been given supervision or instruction concerning use of the appliance by a person responsible for their safety.
20. Children should be supervised to ensure that they **DO NOT** play with the appliance.
21. Use only with specifically designated DEWALT battery packs (see **Important Safety Instructions for All Battery Packs** below for DEWALT-approved battery packs). Use of any battery packs other than those approved by DEWALT may create a risk of injury and fire.

 The lightning flash with arrow head within a triangle is intended to tell the user that parts inside the product are a risk of electric shock to persons.

 The exclamation point within a triangle is intended to tell the user that important operating and servicing instructions are in the user manual supplied with the appliance.

 The double insulation symbol (a square within a square) indicates a Class II electrical appliance and is intended to alert qualified service personnel to use only identical replacement parts in this appliance.

IC RSS210, Issue 8, 2010 This device complies with Industry Canada License-exempt RSS-210. Operation is subject to the following two conditions: (1) this device may not cause interference, and (2) this device must accept any interference, including interference that may cause undesired operation of the device.

FCC This appliance complies with the Federal Communications Commission regulations.

WARNING: Modifications not expressly approved by the manufacturer could void the user authority to operate the equipment under FCC Rules.

NOTE: This equipment has been tested and found to comply with the limits for a class B digital device, pursuant to Part 15 of the FCC Rules. These limits are designed to provide reasonable protection against harmful interference in a residential installation.

This equipment generates, uses and can radiate radio frequency energy and, if not installed and used in accordance with the instructions, may cause harmful interference to radio communications. However, there is no guarantee that interference will not occur in a particular installation. If this equipment does cause harmful interference to radio or television reception, which can be determined by turning the equipment off and on, the user is encouraged to try to correct the interference by one or more of the following measures:

- Reorient or relocate the receiving antenna.
- Increase the separation between the equipment and receiver.
- Connect the equipment to an outlet on a circuit different from that to which the receiver is connected.
- Consult the dealer or an experienced radio/TV technician for help.

 **WARNING:** To reduce the risk of fire or electric shock, **DO NOT** expose this appliance to direct rain or moisture. Use only in dry locations.

 **CAUTION:** To prevent electric shock, match the wide blade of the adaptor plug to the wide slot and fully insert.

LIST OF STANDARDS

The DWST08810 complies with the following standards:

- ANSI/UL60065 (7th Edition Rev. July 24, 2013)
- CAN/CSA C22.2 No. 60065: 2003+A1+A2
- ANSI/UL1310 (6th Edition Rev. December 12, 2014)
- CSA C22.2 No.223-M91 (Rev. September, 2013)
- IC RSS210, Issue 8, 2010
- ICES-003, Issue 5, 2012
- UL2595 (1st Revision) dated on May 22, 2013

- FCC part 15: 2013 (ANSI C63.4:2009)
- FCC ID: YJ7DWST08810
- IC: 9082A-DWST08810

LIST OF SYMBOLS

The labels on this appliance may include the following symbols:

VVolts

AAmperes

WWatts

hhours

Direct current

Class II Construction (double insulated)

ETL Testing Laboratories symbol

Safety alert symbol

IMPORTANT SAFETY INSTRUCTIONS FOR ALL BATTERY PACKS

When ordering replacement battery packs, be sure to include the catalog number and voltage. The DWST08810 is to be used only with DEWALT DCB series 12VDC/20VDC Li-ion rechargeable battery packs with 5Ah max. Use of any other battery packs or any non-rechargeable batteries may create a risk of injury or fire.

Recharge only with the DWST08810 integrated charger, or equivalent. A charger that is suitable for one type of battery pack may create a risk of fire when used with another battery pack.

Note: The battery pack is not fully charged out of the carton. Before using the battery pack and charger, read the safety instructions in the following section and then follow the charging procedures.



THE RBRC™ SEAL

The RBRC™ (Rechargeable Battery Recycling Corporation) seal on the nickel cadmium, nickel metal hydride or lithium ion batteries (or battery packs) indicate that the costs to recycle these batteries (or battery packs) at the end of their useful life have already been paid by DEWALT. In some areas, it is

illegal to place spent nickel cadmium, nickel metal hydride or lithium ion batteries in the trash or municipal solid waste stream, and the RBRC program provides an environmentally conscious alternative. RBRC™, in cooperation with DEWALT and other battery users, has established programs in the United States and Canada to facilitate the collection of spent nickel cadmium, nickel metal hydride or lithium ion batteries. Help protect our environment and conserve natural resources by returning the spent nickel cadmium, nickel metal hydride or lithium ion batteries to an authorized DEWALT service center or to your local retailer for recycling. You may also contact your local recycling center for information on where to drop off the spent battery. RBRC™ is a registered trademark of the Rechargeable Battery Recycling Corporation.

READ ALL INSTRUCTIONS

- **DO NOT charge or use the battery pack in explosive atmospheres, such as in the presence of flammable liquids, gases or dust.** Inserting or removing the battery pack from the charger may ignite the dust or fumes.
- **NEVER force the battery pack into the charger. DO NOT modify the battery pack in any way to fit into a non-compatible charger as battery pack may rupture causing serious personal injury.**
- Charge the battery packs only in designated DEWALT chargers.
- **DO NOT** immerse in water or other liquids.
- **DO NOT store or use the appliance and battery pack in locations where the temperature may reach or exceed 105 °F (40 °C) (such as outside sheds or metal buildings in summer).** For best life store battery packs in a cool, dry location.

 **WARNING:** Fire hazard. **NEVER** attempt to open the battery pack for any reason. If the battery pack case is cracked or damaged, **DO NOT** insert into the charger. **DO NOT** crush, drop or damage the battery pack. **DO NOT** use a battery pack or charger that has received a sharp blow, been dropped, run over or damaged in any way (e.g., pierced with a nail, hit with a hammer, stepped on). Damaged battery packs should be returned to the service center for recycling.

⚠ WARNING: Fire hazard. DO NOT store or carry the battery pack so that metal objects can contact exposed battery terminals. For example, **DO NOT** place the battery pack in aprons, pockets, tool boxes, product kit boxes, drawers, etc., with loose nails, screws, keys, etc. **Transporting batteries can possibly cause fires if the battery terminals inadvertently come in contact with conductive materials such as keys, coins, hand tools and the like.** The US Department of Transportation Hazardous Material Regulations (HMR) actually prohibit transporting batteries in commerce or on airplanes (e.g., packed in suitcases and carry-on luggage) UNLESS they are properly protected from short circuits. So when transporting individual battery packs, make sure that the battery terminals are protected and well insulated from materials that could contact them and cause a short circuit.

SPECIFIC SAFETY INSTRUCTIONS FOR LITHIUM ION (Li-ion)

- **DO NOT incinerate the battery pack even if it is severely damaged or is completely worn out.** The battery pack can explode in a fire. Toxic fumes and materials are created when lithium ion battery packs are burned.
- **If battery contents come into contact with the skin, immediately wash area with mild soap and water.** If battery liquid gets into the eye, rinse water over the open eye for 15 minutes or until irritation ceases. Additionally, seek medical attention. The battery electrolyte is composed of a mixture of liquid organic carbonates and lithium salts.
- **Contents of opened battery cells may cause respiratory irritation.** Provide fresh air. If symptoms persist, seek medical attention.
- **DO NOT expose a battery pack or appliance to fire or excessive temperature.** Exposure to fire or temperature above 265 °F (130 °C) may cause explosion.

⚠ WARNING: Burn hazard. Battery liquid may be flammable if exposed to spark or flame.

Important Safety Instructions for All Battery Chargers

SAVE THESE INSTRUCTIONS: This manual contains important safety and operating instructions for battery chargers.

- Before using the charger, read and understand all instructions and cautionary markings on the charger, battery pack and product using the battery pack.
- **⚠ WARNING:** Shock hazard. **DO NOT** allow any liquid to get inside the charger. Electric shock may result.
- **⚠ CAUTION:** Burn hazard. To reduce the risk of injury, charge only DEWALT rechargeable battery packs. Other types of batteries may overheat and burst resulting in personal injury and property damage.

NOTICE: When battery pack is not in use, keep it away from other metal objects. Alternatively, with the charger plugged into the power supply, the charger can be shorted or ignited by foreign material. Foreign materials or metal objects of a conductive nature, such as, but not limited to, grinding dust, metal chips, steel wool, aluminum foil or any buildup of metallic particles should be kept away from the charger cavities at all times.

Always unplug the AC/DC power adaptor from the outlet and remove the battery pack from the battery pack receptacle before attempting to clean the charger.

- **DO NOT attempt to charge the battery pack with any chargers other than a compatible DEWALT charger.** The charger and battery pack are specifically designed to work together.
- **This charger is not intended for any uses other than charging DEWALT rechargeable batteries.** Any other uses may result in risk of fire, electric shock or electrocution.
- **DO NOT expose the charger to direct water source and DO NOT immerse in water.**

- **Pull by the plug rather than the cord when disconnecting the charger.** This will reduce the risk of damage to the electric plug and cord.
- **Make sure that the cord is located so that it will not be stepped on, tripped over or otherwise subjected to damage or stress.**
- **DO NOT use an extension cord unless it is absolutely necessary.** Use of improper extension cord could result in risk of fire, electric shock or electrocution.
- **When operating a charger outdoors, always provide a dry location and use an extension cord suitable for outdoor use.** Use of a cord suitable for outdoor use reduces the risk of electric shock.
- **DO NOT place any object on top of the charger.** Place the charger in a position away from any heat source.
- **DO NOT operate the charger with a damaged cord or plug.**
- **DO NOT operate the charger if it has received a sharp blow, been dropped or otherwise damaged in any way.** Take it to an authorized service center.
- **DO NOT disassemble the charger; take it to an authorized service center when service or repair is required.** Incorrect reassembly may result in a risk of electric shock, electrocution or fire.
- **Disconnect the charger from the outlet before attempting any cleaning. This will reduce the risk of electric shock.** Removing the battery pack will not reduce this risk.
- **NEVER** attempt to connect 2 chargers together.
- **The charger is designed to operate on 24VDC. DO NOT attempt to use it with any other power supply AC/DC power adaptor other than that supplied with the appliance.the appliance.**

APPLIANCE DESCRIPTION

1. Front speakers (2x)
2. Carrying handle
3. Control panel
4. Top compartment latches (4x)
5. Top compartment cover
6. Stacking latches (2x)

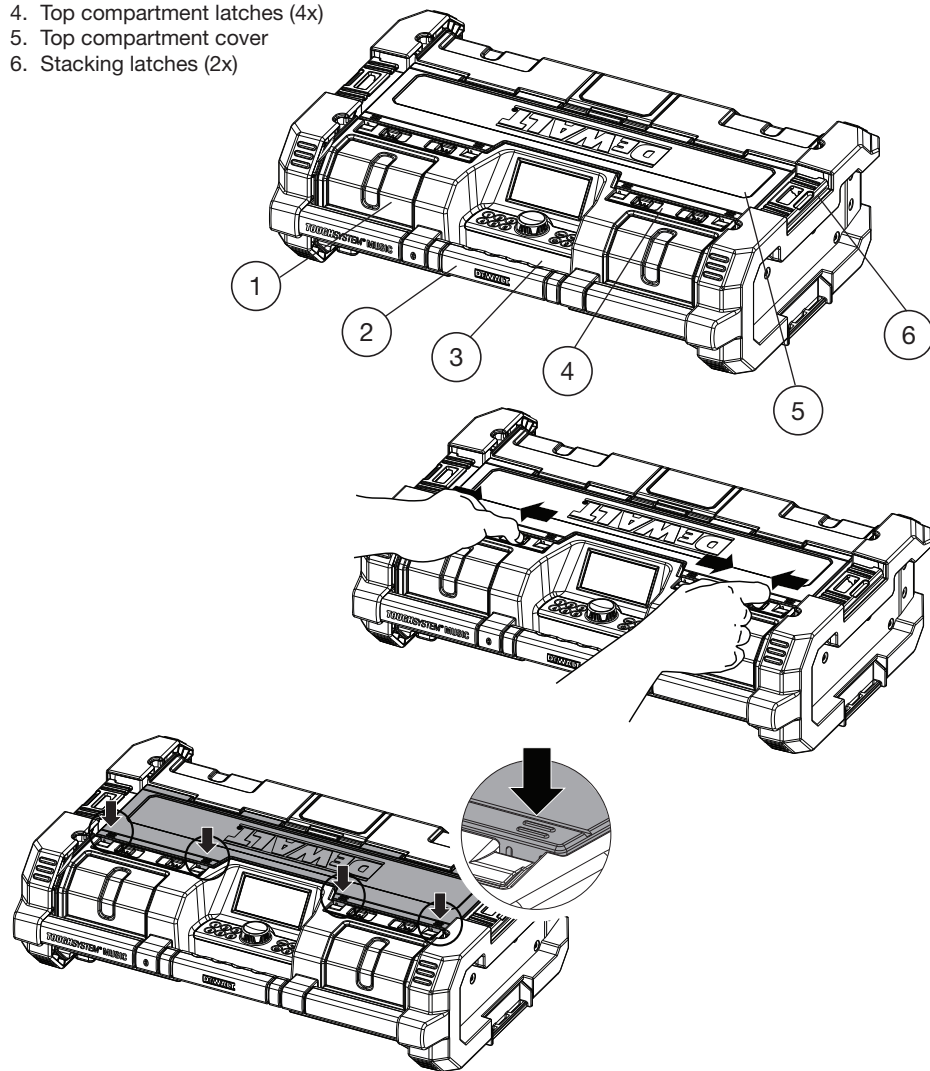

- To open the top compartment, release the 4 locking latches below the compartment yellow cover (item 4) and open it.
 - To close the compartment, push down on all 4 corners of the yellow cover.
- NOTE:** When correctly closed, the compartment protects its contents from dust, debris and light rain.

Figure 1. Front View

1. Rear loudspeakers (2x)
2. Power-in port (24VDC)
3. Battery pack cover latches (2x)
4. Cart locking back hook
5. Battery pack cover
6. Slots for cart

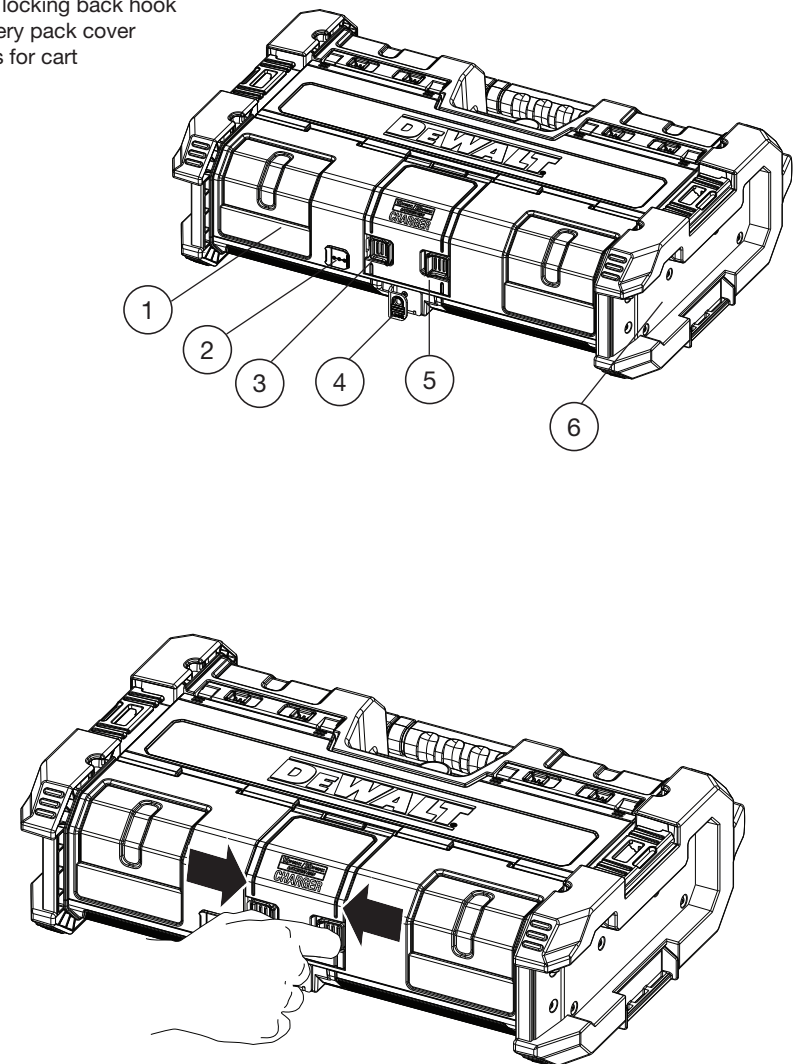

- To open the battery compartment, release the 2 locking latches of the compartment yellow cover (item 3) and swing it open.
- To close the compartment, push the cover closed.

Figure 2. Rear View

1. AC/DC power adaptor
2. Auxiliary jack (3.5 mm)
3. USB power/charging port
4. Top compartment cover

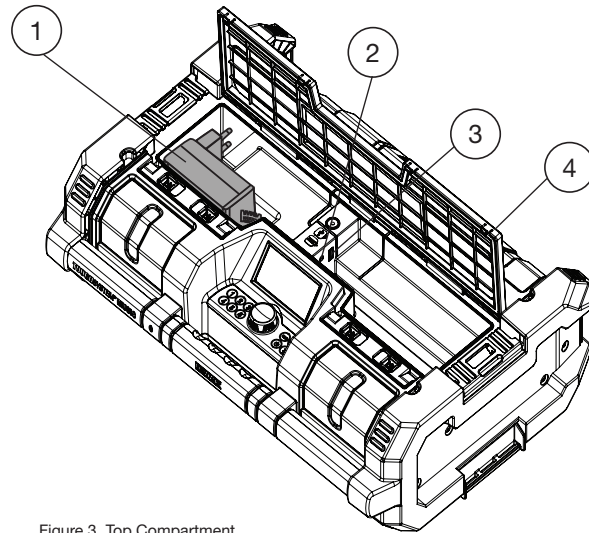

Figure 3. Top Compartment

1. Battery pack (not included)
2. Battery pack receptacle
3. Battery pack cover

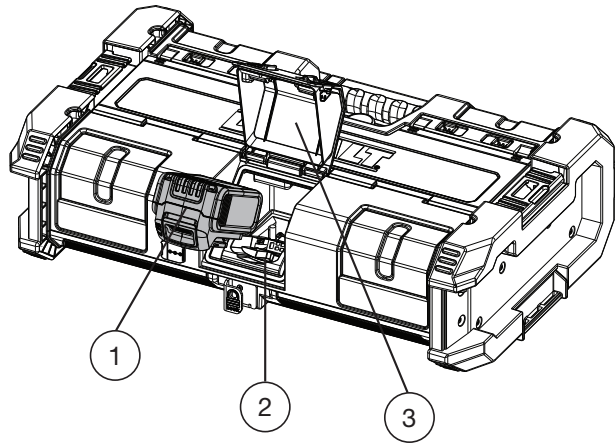

Figure 4. Battery Compartment

1. LCD Display
 - Audio source
 - Reception (radio mode)
 - Bluetooth (Bluetooth mode)
 - Battery status
2. Radio preset buttons
3. Selection dial
4. Mode buttons
 - Power On/Off (⏻)
 - Source selection (SRC)
 - Back (⏪)
 - Bluetooth (📶)

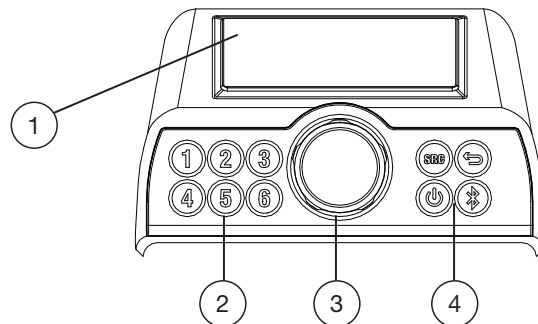

Figure 5. Control Panel

CHARGING

The DWST08810 can charge only DEWALT DCB series 12VDC/20VDC Li-ion rechargeable battery packs with 5Ah max. Use of any other battery packs or any non-rechargeable batteries may create a risk of injury or fire. Be sure to read all safety instructions before using this appliance for charging your battery pack.

IMPORTANT CHARGING NOTES

1. Longest life and best performance can be obtained if the battery pack 1. is charged when the air temperature is between 65 °F and 75 °F (18–24 °C). **DO NOT** charge the battery pack in an air temperature below +40 °F (+4.5 °C), or above +105 °F (+40.5 °C). This is important and will prevent serious damage to the battery pack.
2. The charger and battery pack may become warm to the touch while charging. This is a normal condition, and does not indicate a problem. To facilitate the cooling of the battery pack after use, avoid placing the charger or battery pack in a warm environment such as in a metal shed or an uninsulated trailer.
3. A cold battery pack will charge at about half the rate of a warm battery pack. The battery pack will charge at that slower rate throughout the entire charging cycle and will not return to maximum charge rate even if the battery pack warms.
4. If the battery pack does not charge properly:
 - a. Check operation of receptacle by plugging in a lamp or other appliance;
 - b. Check to see if receptacle is connected to a light switch which turns power off when you turn out the lights;
 - c. Move the charger and battery pack to a location where the surrounding air temperature is approximately 65–75 °F (18–24 °C);
 - d. If charging problems persist, take the battery pack and charger to your local service center.
5. The battery pack should be recharged when it fails to produce sufficient power on jobs which were easily done previously. **DO NOT CONTINUE** to use the pack under these conditions. You

may also charge a partially used pack with no adverse effect on the battery pack.

6. Foreign materials of a conductive nature such as, but not limited to, grinding dust, metal chips, steel wool, aluminum foil, or any buildup of metallic particles should be kept away from charger cavities. Always unplug the charger from the power supply before attempting to clean.
7. **DO NOT** freeze or immerse the charger in water or any other liquid.

⚠ **WARNING:** Shock hazard. Don't allow any liquid to get inside the charger. **Electric shock** may result.

⚠ **WARNING:** Burn hazard. **DO NOT** submerge the battery pack in any liquid or allow any liquid to enter the battery pack. **NEVER** attempt to open the battery pack for any reason. If the plastic housing of the battery pack breaks or cracks, return to a service center for recycling.













⚠ **CAUTION:** Danger of explosion if battery is incorrectly replaced. **Replace only with the same or equivalent type.**

STORAGE RECOMMENDATIONS

1. The best storage place is one that is cool and dry, away from direct sunlight and excess heat or cold.
2. For long-term storage, it is recommended to store a fully charged battery pack in a cool dry place out of the charger for optimal results. **NOTE:** Battery packs should not be stored completely depleted of charge. The battery pack will need to be recharged before use.

SAVE THESE INSTRUCTIONS FOR FUTURE USE

LCD INDICATORS

When the appliance is turned OFF		When the appliance is turned ON	
When charging a battery pack while the appliance is turned off, a large battery image is displayed in the center of the LCD screen showing the battery pack charging status.		When the DWST08810 is on, indicators for the power supply and the battery status are displayed on the lower right portion of the LCD screen.	
	Battery pack is empty		Appliance is operating via the AC/DC power adaptor
	Battery pack level is low		Battery level is low
	Battery pack is partially charged		Battery is partially charged
	Battery pack is fully charged		Battery is fully charged
	Hot/Cold Delay This charger has a hot/cold delay feature: when the charger detects a battery that is hot, it automatically starts a delay, suspending charging until the battery has cooled. After the battery has cooled, the charger automatically switches to the pack charging mode. This feature ensures maximum battery life.		Hot/Cold delay of charging
	Faulty Battery Packs This charger will not charge a faulty battery pack. The charger will indicate faulty battery pack by displaying an X on the LCD battery image. If this occurs, re-insert the battery pack into the charger. If the problem persists, try a different battery pack to determine if the charger is working properly. If the new pack charges correctly, then the original pack is defective and should be returned to a service center or other collection site for recycling. If the new battery pack elicits the same trouble indication as the original, have the charger and the battery pack tested at an authorized service center. NOTE: This could also mean a problem with a charger		Problem with the battery pack or charger

WARNING: To reduce the risk of injury, turn the appliance off and disconnect it from the power outlet when not in use and when making repairs. **DO NOT** attempt to disassemble the unit; take it to an authorized service center when service or repair is required.

CHARGING A BATTERY PACK

The DWST08810 includes a top compartment that is mainly used to store and protect the AC/DC power adaptor when not in-use.

1. Open the top compartment to take out the AC/DC power adaptor (see Figure 1 and Figure 3).
2. Plug the charger AC/DC power adaptor into an appropriate outlet and connect it to the DWST08810 power-in port before inserting the battery pack (see Figure 2).
3. Open the battery pack cover by releasing its two latches (see Figure 2).

4. Insert the battery pack (not included) into the charger, making sure the pack is fully seated in the charger (see Figure 4). The battery indicator image will blink continuously, indicating that battery charging is in process.
NOTE: Close the battery pack cover and check it is tightly closed.
5. The completion of charging will be indicated by a steady battery indicator image. The pack is fully charged and may be used at this time or left in the charger.

OPERATION

The DWST08810 will operate when connected with the AC/DC power adaptor and/or when operated solely on battery power.







NOTE: When the DWST08810 is connected by the supplied power supply unit to the outlet it will charge the installed battery. Unplugged, the appliance can run up to 8 hours on a fully charged battery using a premium 20V MAX* 2 Ah Li-ion battery. Using batteries of lower voltage and amp hours will yield less run time.

This appliance can be operated in the vertical or horizontal position.

* With respect to 20V MAX* - Maximum initial battery voltage (measured without a workload) is 20 volts. Nominal voltage is 18.

Button Functions

The front panel includes a selection dial and pushbuttons.

-  Selection dial (the selection dial has more than one function)
-  On/Off button
-  Back button
-  Source selection button
-  Bluetooth button
-  Preset buttons

Powering ON and OFF

Press the POWER button () for 1 second. The appliance turns on to the last selected audio source.

Press the POWER button () for 3 seconds. The appliance turns off.

Volume Adjustment

⚠ WARNING: Excessive sound level can cause hearing loss.

NOTE: The volume is set and saved separately for each of the audio source types.

Turn the dial (●) clockwise to increase the volume. To decrease the volume, turn counterclockwise.

Back Button (⏪)

After entering any one of the screens, press the **Back** button (⏪) to return to the previous screen.

Audio Source Select (SRC)

To choose one of the audio sources (FM1, FM2, AM, AUX or Bluetooth) push the source selection button (SRC) until the desired source is found. For example, if the radio is on FM1, seen in upper left portion of LCD display, push the source button three times to change to AUX.

MAIN MENU (General Setup)

General Setup can be accessed from each of the selected audio sources by:

1. Pressing the **selection dial** (●).
2. Rotating the **selection dial** clockwise until **Main Menu** is reached
3. Pressing the **selection dial** to access the **Main Menu**.

From the main menu the following actions can be performed:

- **Sound:** Sound: tone adjust: Bass, Treble and Mid
- **Language:** select the interface Language
- **Brightness:** adjust the screen Brightness
- **Restore to default**

TUNER SETUP

The DWST08810 can be tuned to FM and AM radio frequencies with the option of saving up to twelve (12) FM and six (6) AM preset stations. After setting and saving the preset stations, pressing a preset button (1-6) instantly changes the frequency to the desired station. Finding a desired frequency can be performed in one of two methods: Auto Scan or Manual Tune.

Auto Scan

1. Press the audio source button (SRC) until the required source is reached (FM1, FM2, AM).
2. Press the selection dial (●) to enter the **Main Menu** (see **General Setup**).
3. Rotate the selection dial clockwise until Auto Scan is reached and press to select. The Auto Scan begins searching for the closest strong, clear signal.
 - Rotate the dial clockwise to scan up the frequencies.
 - Rotate the dial counterclockwise to scan down the frequencies.
4. Once a desired frequency is found, save it to one of the channel preset buttons (see **Setting the Preset Buttons**).

Manual Tune

1. Select the required audio source and enter the **Main Menu** (see **General Setup**).
2. Rotate the **selection dial** clockwise and press it to select **Manual Tune**.
3. Rotate the **selection dial** clockwise to go up the frequencies or counterclockwise to go down the frequencies, until the desired frequency is reached.
4. Once a desired frequency is found, save it to one of the channel preset buttons (see **Setting the Preset Buttons**).

Setting the Preset Buttons

1. Set the radio to the desired station/frequency (see **Auto Scan** or **Manual Tune**).
2. Press and hold the desired preset button (1-6) until a message ">>P#" is displayed. The station is saved to the displayed preset button number (#).
3. Repeat steps 1 and 2 to set additional preset stations.
4. Press the selection dial to return to the Audio Source screen. The selected station is indicated on the LCD screen (button 2 in the example below).

IMPORTANT RADIO NOTES

1. Reception will vary depending on location and strength of radio signal.
2. Running the radio while connected to certain generators may cause background noise.
3. AM reception will most likely be clearer when powered by a battery pack.

Adjusting Sound Preferences

Sound preferences can be adjusted by changing the equalization of the **Bass**, **Treble** or **Mid**.

1. Press the **selection dial** (●).
2. Rotate the **selection dial** clockwise until **Main Menu** is reached.
3. Press the **selection dial** to access the **Main Menu**.
4. Press the **selection dial** again to enter the **Sound** settings screen.
5. Adjust to the desired setting by rotating the selection dial clockwise/ counterclockwise.
6. Press the selection dial to scroll through the sound setup options. Pressing (⏪) saves the selected setup.

Playing Audio From An External Device (AUX/Bluetooth)

The DWST08810 can be used to play sound from an external device, through its built-in speakers, in one of two connection options:

- Auxiliary
- Bluetooth

NOTE: The top compartment can also be used to store, protect and charge some portable audio devices, such as a smart phone or MP3 player. The USB power port can charge/power most devices that can accept power through a USB charging port (5V/1A).

Connecting an Auxiliary Device

1. Connect a 3.5 mm audio cable between the auxiliary input jack and the output jack of your audio device.
2. Press the **audio source** button (SRC) until **AUX** is displayed.
3. Operate the audio through the connected device.

Connecting a Device through Bluetooth

The DWST08810 can connect to Bluetooth capable audio devices through Bluetooth communication.

NOTE: The Bluetooth mode can store up to 8 users.

1. Enable the Bluetooth of the audio device to be connected.
2. Press the **audio source** button (SRC) until the **Bluetooth** symbol is displayed (📶), or press the **Bluetooth button** (📶) This operation enters the Bluetooth mode. The Bluetooth button (📶) blinks slowly.
3. Press the **Bluetooth** button (📶) for 3 seconds to make it discoverable. A **discoverable signal** sounds and the Bluetooth button (📶) blinks fast.
4. Look for the DWST08810 (display name: **ToughSystem Music**) on the audio device to be connected, and select it. Once connected a **connected signal** sounds. The Bluetooth symbol is displayed on the LCD screen and the Bluetooth button lights in steady blue.
5. Operate the audio through the connected device. The next time this device is in its Bluetooth **ON** mode, it will automatically discover and connect to the DWST08810.

NOTE: The appliance connects to the last connected device. A **connected signal** sounds.

- If the last connected device is not available, the **Bluetooth** button blinks until found by one of the other previously connected devices.

NOTE: To disconnect from a device and become discoverable for other devices, press the Bluetooth button (📶) for 3 seconds, or press the selection dial and select Make Discoverable.

TROUBLESHOOTING

Weak Battery Packs

Weak batteries will continue to function but should not be expected to perform as well. When the appliance is powered by a battery pack and its charging level falls below 10%, the low battery indicator is displayed.

Battery Pack Protection

To protect the life of the battery pack, the appliance will shut off when the battery's charging level becomes too low. If this happens, connect the DWST08810 to an outlet with the AC/DC power adaptor and charge the battery pack.

Music Stops

When dropping the appliance in its vertical position the battery pack may fall out of its receptacle. If the music is operated by the battery pack, the music will stop. To resume, open the battery pack cover and reposition the battery pack.

MAINTENANCE

⚠ WARNING: To reduce the risk of injury, turn appliance off and disconnect it from power source before performing any maintenance procedures or when making repairs. **DO NOT** attempt to disassemble the unit; take it to an authorized service center when service or repair is required.

Cleaning

⚠ WARNING: Disconnect the charger from the AC outlet before cleaning. Dirt and grease may be removed from the exterior of the appliance using a cloth or soft non-metallic brush.

⚠ WARNING: Blow out dirt and dust with clean, dry air at least once a week. To minimize the risk of eye injury, always wear ANSI Z87.1 approved eye protection when performing this.

⚠ WARNING: NEVER use solvents or other harsh chemicals for cleaning the non-metallic parts of the appliance. These chemicals may weaken the plastic materials used in these parts. Use a cloth dampened only with water and mild soap. **NEVER** let any liquid get inside the appliance; **NEVER** immerse any part of the appliance into a liquid.

ACCESSORIES

⚠ WARNING: Since accessories, other than those offered by DEWALT, have not been tested with this appliance,

use of other such accessories could be hazardous. To reduce the risk of injury, only DEWALT accessories should be used with this appliance. Accessories for use with the DWST08810 are available at extra cost from your local dealer or authorized service center. If you need assistance in locating any accessory, please contact DEWALT Industrial Tool Co., 701 East Joppa Road, Baltimore, MD 21286, call 1-800-4-DEWALT (1-800-433-9258) or visit our website: www.dewalt.com.

REPAIRS

The battery packs are not serviceable. To assure product SAFETY and RELIABILITY, any repairs, maintenance and adjustment should be performed by a DEWALT factory service center, a DEWALT authorized service center or other qualified service personnel. Always use identical replacement parts.

REGISTER ONLINE

Thank you for your purchase. Register your product now for:

- **WARRANTY SERVICE:** Registering your product will help you obtain more efficient warranty service in case there is a problem with your product.
- **CONFIRMATION OF OWNERSHIP:** In case of an insurance loss, such as fire, flood or theft, your registration of ownership will serve as your proof of purchase
- **FOR YOUR SAFETY:** Registering your product will allow us to contact you in the unlikely event a safety notification is required under the Federal Consumer Safety Act.

Register online at www.dewalt.com/register.

THREE YEAR LIMITED WARRANTY

DEWALT will repair, without charge, any defects due to faulty materials or workmanship for three years from the date of purchase. This warranty does not cover part failure due to normal wear or abuse. For further detail of warranty coverage and warranty repair information, visit www.dewalt.com or call 1-800-4-DEWALT (1-800-433-9258). This warranty does not apply to accessories or damage caused where repairs have been made or attempted by others. This warranty gives you specific legal rights and you may have other rights which vary in certain states or provinces.

In addition to the warranty, this DEWALT product is covered by our:

1 YEAR FREE SERVICE DEWALT

DEWALT will maintain the product and replace worn parts caused by normal use, for free, any time during the first year after purchase.

DEWALT BATTERY PACKS

Product warranty voided if the battery pack is tampered with in any way. DEWALT is not responsible for any injury caused by tampering and may prosecute warranty fraud to the fullest extent permitted by law.

90 DAY MONEY BACK GUARANTEE

If you are not completely satisfied with the performance of your DEWALT DWST08810, ToughSystem® Music + Charger, for any reason, you can return it within 90 days from the date of purchase with a receipt for a full refund – no questions asked.

LATIN AMERICA: This warranty does not apply to products sold in Latin America. For products sold in Latin America, see country specific warranty information, call the local company or see website for warranty information.

FREE WARNING LABEL REPLACEMENT: If your **WARNING** labels become illegible or are missing, call 1-800-4-DEWALT (1-800-433-9258) for a free replacement.

(APR15) Part No. DWST08810 Copyright © 2015 DeWALT

The following are trademarks for one or more DEWALT power tools: the yellow and black color scheme; the "D" shaped air intake grill; the array of pyramids on the handgrip; the kit box configuration; and the array of lozenge-shaped humps on the surface of the tool.



DeWALT Industrial Tool Co.,
701 East Joppa Road, Baltimore, MD 21286
1-800-4-DEWALT (1-800-433-9258)
www.dewalt.com
V1.0615

14657 02/16